



DEPARTMENT OF REGULATORY AND ECONOMIC RESOURCES (RER)  
 BOARD AND CODE ADMINISTRATION DIVISION

**NOTICE OF ACCEPTANCE (NOA)**

MIAMI-DADE COUNTY  
 PRODUCT CONTROL SECTION  
 11805 SW 26 Street, Room 208  
 Miami, Florida 33175-2474  
 T (786) 315-2590 F (786) 315-2599  
[www.miamidade.gov/economy](http://www.miamidade.gov/economy)

**Eagle Roofing Products LLC**  
**1575 East C.R. 470**  
**Sumterville, FL 33585**

**SCOPE:**

This NOA is being issued under the applicable rules and regulations governing the use of construction materials. The documentation submitted has been reviewed and accepted by Miami-Dade County RER -Product Control Section to be used in Miami-Dade County and other areas where allowed by the Authority Having Jurisdiction (AHJ).

This NOA shall not be valid after the expiration date stated below. The Miami-Dade County Product Control Section (in Miami-Dade County) and/or the AHJ (in areas other than Miami-Dade County) reserve the right to have this product or material tested for quality assurance purposes. If this product or material fails to perform in the accepted manner, the manufacturer will incur the expense of such testing and the AHJ may immediately revoke, modify, or suspend the use of such product or material within their jurisdiction. RER reserves the right to revoke this acceptance, if it is determined by Miami-Dade County Product Control Section that this product or material fails to meet the requirements of the applicable building code.

This product is approved as described herein, and has been designed to comply with the Florida Building Code including the High Velocity Hurricane Zone of the Florida Building Code.

**DESCRIPTION: High Profile Concrete Tile**

**LABELING:** Each unit shall bear a permanent label with the manufacturer's name or logo, city, state and following statement: "Miami-Dade County Product Control Approved", unless otherwise noted herein.

**RENEWAL** of this NOA shall be considered after a renewal application has been filed and there has been no change in the applicable building code negatively affecting the performance of this product.

**TERMINATION** of this NOA will occur after the expiration date or if there has been a revision or change in the materials, use, and/or manufacture of the product or process. Misuse of this NOA as an endorsement of any product, for sales, advertising or any other purposes shall automatically terminate this NOA. Failure to comply with any section of this NOA shall be cause for termination and removal of NOA.

**ADVERTISEMENT:** The NOA number preceded by the words Miami-Dade County, Florida, and followed by the expiration date may be displayed in advertising literature. If any portion of the NOA is displayed, then it shall be done in its entirety.

**INSPECTION:** A copy of this entire NOA shall be provided to the user by the manufacturer or its distributors and shall be available for inspection at the job site at the request of the Building Official.

This NOA revises NOA No.17-0822.15 and consists of pages 1 through 7.

The submitted documentation was reviewed by *Freddy Semino* 



NOA No. 18-0523.04  
 Expiration Date: 10/05/21  
 Approval Date: 07/19/18  
 Page 1 of 7

## ROOFING ASSEMBLY APPROVAL

**Category:** Roofing  
**Sub Category:** Roofing Tiles  
**Material:** Concrete

### 1. SCOPE:

This approves a new roofing system using **High Profile Concrete Tile** as manufactured by **Eagle Roofing Products LLC** in **Sumterville, FL** and described in Section 2 of this Notice of Acceptance. For use in locations where the pressure requirements, as determined by applicable Building Code, do not exceed the design pressure values obtained by calculations in compliance with RAS 127 using the values listed in section 4 herein. The attachment calculations shall be done as a moment based system.

### 2. PRODUCT DESCRIPTION:

<u>Manufactured by Applicant</u>	<u>Dimensions</u>	<u>Test Specifications</u>	<u>Product Description</u>
<b>High Profile Concrete Tile</b>	Length = 17" Width = 12 1/4" Thickness = 1/2"	TAS 112 Type 1a Class III	High profile concrete roof tile. For direct deck or battened nail-on applications.
<b>Trim Pieces</b>	Length = varies Width = varies varying thickness	TAS 112	Accessory trim, concrete roof pieces for use at hips, rakes, ridges and valley terminations. Manufactured for each tile profile.

#### 2.1 PRODUCTS MANUFACTURED BY OTHERS

<u>Product Name</u>	<u>Product Description</u>	<u>Manufacturer (With Current NOA)</u>
ICP Adhesives Polyset® AH-160	Two component polyurethane foam adhesive.	ICP Adhesives and Sealants, Inc.
TILE BOND™ Roof Tile Adhesive	Single component polyurethane foam roof tile adhesive.	The Dow Chemical Company
DAP Foam Touch N Seal StormBond® 2 Roof Tile Adhesive	Two component polyurethane foam adhesive.	The Dow Chemical Company

#### 2.2 MANUFACTURING LOCATION

2.2.1. Sumterville, FL



NOA No. 18-0523.04  
Expiration Date: 10/05/21  
Approval Date: 07/19/18  
Page 2 of 7

### 2.3 EVIDENCE SUBMITTED:

<u>Test Agency</u>	<u>Test Identifier</u>	<u>Test Name/Report</u>	<u>Date</u>
PRI Asphalt Technologies	ERPF-001-02-03	TAS-112	Aug. 2006
Redland Technologies	7161-03 Appendix III	Static Uplift Testing TAS 102 & 102(A)	Dec. 1991
Redland Technologies	Letter Dated Aug. 1, 1994	Wind Tunnel Testing TAS 108 (Nail-On)	Aug. 1994
Redland Technologies	P09647-01	Wind Tunnel Testing TAS 108 (Mortar Set)	Aug. 1994
Redland Technologies	P0402	Withdrawal Resistance Testing of screw vs. smooth shank nails	Sept. 1993
The Center for Applied Engineering, Inc.	94-083	Static Uplift Testing TAS 101 (Adhesive Set)	April 1994
The Center for Applied Engineering, Inc.	94-084	Static Uplift Testing TAS 101 (Mortar Set)	May 1994
The Center for Applied Engineering, Inc.	25-7094-(3, 6 & 9)	Static Uplift Testing TAS 102	Oct. 1994
The Center for Applied Engineering, Inc.	25-7120-(1 & 2)	Static Uplift Testing TAS 102	Nov. 1994
The Center for Applied Engineering, Inc.	25-7183-(3 & 4)	Static Uplift Testing TAS 102	Feb. 1995
The Center for Applied Engineering, Inc.	25-7214-(3, 4, &7)	Static Uplift Testing TAS 102	March, 1995
The Center for Applied Engineering, Inc.	25-7804-4	Static Uplift Testing TAS 102	Sep. 1996
Celotex Corporation Testing Services	520111-3	Static Uplift Testing TAS 101	Dec. 1998
Celotex Corporation Testing Services	520191-2-1	Static Uplift Testing TAS 101	March 1999
Walker Engineering, Inc.	Calculations	Aerodynamic Multiplier	Sep. 2006
ATL of South Florida	RT1211.02-15	TAS-112	12/17/15
ATL of South Florida	RT0706.03.17	TAS-112	09/25/17
PRI Construction Materials	DAPF-001-02-01	TAS 101	11/30/17



**3. LIMITATIONS:**

- 3.1 Fire classification is not part of this acceptance.
- 3.2 For mortar or adhesive set tile applications, a static field uplift test in accordance with TAS 106 shall be required, refer to applicable Building Code.
- 3.3 Applicant shall retain the services of a Miami-Dade County Certified Laboratory to perform quarterly test in accordance with TAS 112, appendix 'A'. Such testing shall be submitted to the Miami-Dade County Product Control Section for review.
- 3.4 Minimum underlayment shall be in compliance with the applicable Roofing Applications Standards listed section 4.1 herein.
- 3.5 30/90 hot mopped underlayment applications may be installed perpendicular to the roof slope unless stated otherwise by the underlayment material manufacturers published literature.
- 3.6 This acceptance is for wood deck applications. Minimum deck requirements shall be in compliance with applicable Building Code.
- 3.7 All products listed herein shall have a quality assurance audit in accordance with the Florida Building Code and Rule 61G20-3 of the Florida Administrative Code.

**4. INSTALLATION**

- 4.1 Eagle Roofing Products LLC, High Profile Concrete Tile and its components shall be installed in strict compliance with Roofing Application Standard RAS 118, RAS 119 and RAS 120.
- 4.2 Data For Attachment Calculations

**Table 1: Average Weight (W) and Dimensions (l x w)**

Tile Profile	Weight-W (lbf)	Length-l (ft)	Width-w (ft)
High Profile Concrete Tile	10	1.417	1.04

**Table 2: Aerodynamic Multipliers -  $\lambda$  (ft<sup>3</sup>)**

Tile Profile	$\lambda$ (ft <sup>3</sup> ) Batten Application	$\lambda$ (ft <sup>3</sup> ) Direct Deck Application
High Profile Concrete Tile	0.300	0.277

**Table 3: Restoring Moments due to Gravity -  $M_g$  (ft-lbf)**

Tile Profile	3":12"		4":12"		5":12"		6":12"		Greater than 7":12"	
	Battens	Direct Deck	Battens	Direct Deck	Battens	Direct Deck	Battens	Direct Deck	Battens	Direct Deck
High Profile Concrete Tile	6.68	6.99	6.57	6.88	6.44	6.73	6.28	6.56	6.10	6.38



**Table 4: Attachment Resistance Expressed as a Moment -  $M_f$  (ft-lbf)  
for Nail-On Systems**

Tile Profile	Fastener Type	Direct Deck (min 15/32" plywood)	Direct Deck (min. 19/32" plywood)	Battens
High Profile Concrete Tile	2-10d Ring Shank Nails	28.6	41.2	19.4
	1-10d Smooth or Screw Shank Nail	5.1	6.8	2.8
	2-10d Smooth or Screw Shank Nails	6.9	9.2	7.3
	1 #8 Screw	20.7	20.7	18.1
	2 #8 Screw	43.2	43.2	29.8
	1-10d Smooth or Screw Shank Nail (Field Clip)	23.1	23.1	19.0
	1-10d Smooth or Screw Shank Nail (Eave Clip)	29.3	29.3	24.0
	2-10d Smooth or Screw Shank Nails (Field Clip)	27.6	27.6	38.6
	2-10d Smooth or Screw Shank Nails (Eave Clip)	38.1	38.1	41.8
	2-10d Ring Shank Nails <sup>1</sup>	33.1	48.1	45.2

1. Installation with a 4" tile headlap and fasteners are located a min. of 2½" from head of tile.

**Table 5: Attachment Resistance Expressed as a Moment  $M_f$  (ft-lbf)  
for Two Patty Adhesive Set Systems**

Tile Profile	Tile Application	Minimum Attachment Resistance
High Profile Concrete Tile	Adhesive	29.3 <sup>2</sup> 49 <sup>3</sup>

1 See manufactures component approval for installation requirements.  
 2 The Dow Chemical Company TileBond Average weight per patty 10.7 grams.  
 ICP Adhesives Polyset® AH-160. Average weight per patty 8 grams.  
 3 DAP Foam Touch N Seal StormBond 2 Roof Tile Adhesive average weight per patty 8 grams.

**Table 6: Attachment Resistance Expressed as a Moment -  $M_f$  (ft-lbf)  
for Single Patty Adhesive Set Systems**

Tile Profile	Tile Application	Minimum Attachment Resistance
High Profile Concrete Tile	ICP Adhesives Polyset® AH-160	66.5 <sup>3</sup>
	ICP Adhesives Polyset® AH-160	38.7 <sup>4</sup>

3 Large patty placement of 63grams of Polyset® AH-160.  
 4 Medium patty placement of 24grams of Polyset® AH-160.



**Table 7: Attachment Resistance Expressed as a Moment -  $M_f$  (ft-lbf)  
for Mortar Set Systems**

Tile Profile	Tile Application	Attachment Resistance
High Profile Concrete Tile	Mortar Set <sup>5</sup>	24.5
5 Tile-Tite Roof Tile Mortar.		

**5. LABELING :**

All tiles shall bear the imprint or identifiable marking of the manufacturer's name or logo (See **Detail Below**), or following statement: "Miami-Dade County Product Control Approved".



(LOCATED ON UNDERSIDE OF TILE)

OR

**EAGLE FL**

(LOCATED ON FRONTSIDE OF TILE)

**High Profile Concrete Tile LABEL, SUMTERVILLE PLANT**



## 6. BUILDING PERMIT REQUIREMENTS:

6.1 Application for building permit shall be accompanied by copies of the following:

6.1.1 This Notice of Acceptance.

6.1.2 Any other documents required by AHJ or applicable Building Code in order to properly evaluate the installation of this system.

### PROFILE DRAWING

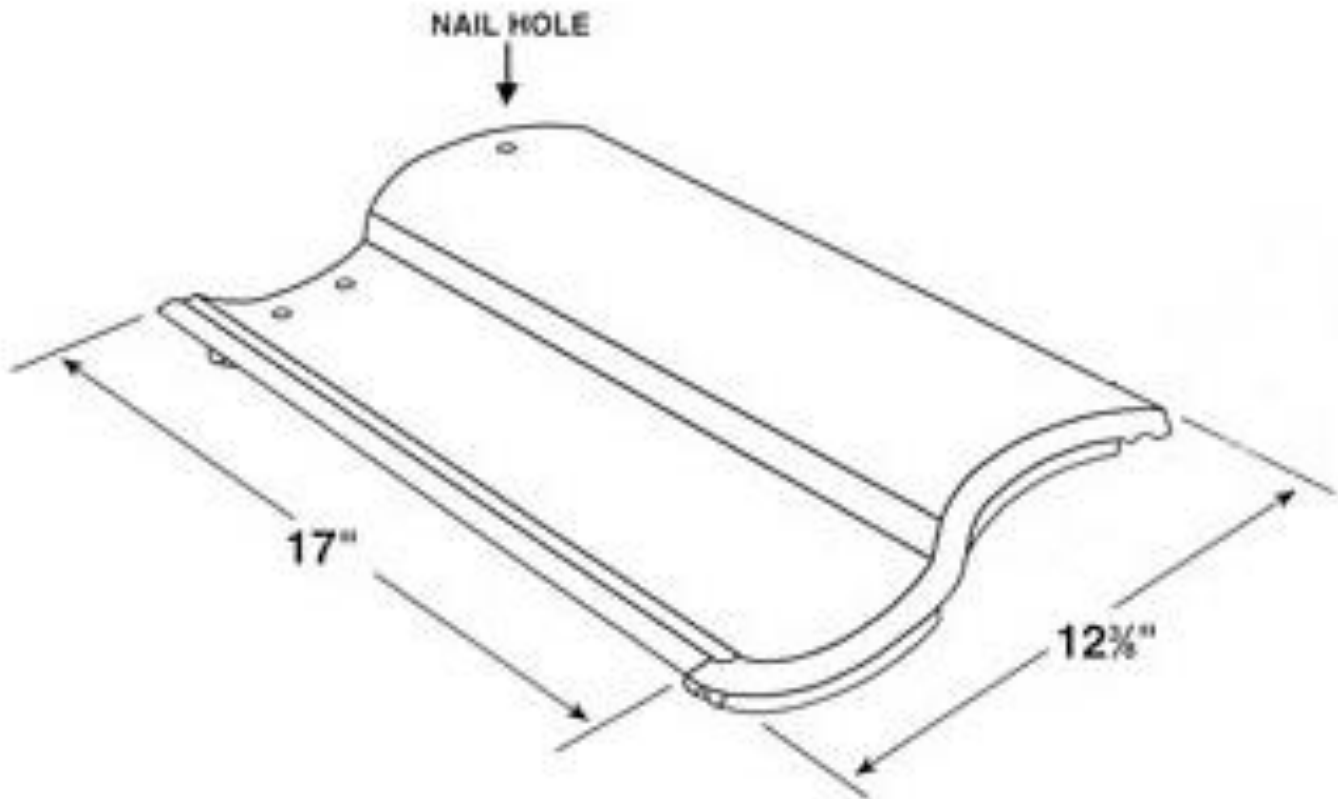

**High Profile Concrete Tile**

**END OF THIS ACCEPTANCE**



NOA No. 18-0523.04  
Expiration Date: 10/05/21  
Approval Date: 07/19/18  
Page 7 of 7



**NOA No. 18-0523.04**  
**Expiration Date: 10/05/21**  
**Approval Date: 07/19/18**  
**Page 8 of 7**