



DEPARTMENT OF REGULATORY AND ECONOMIC RESOURCES (RER)  
BOARD AND CODE ADMINISTRATION DIVISION  
**NOTICE OF ACCEPTANCE (NOA)**

MIAMI-DADE COUNTY  
PRODUCT CONTROL SECTION  
11805 SW 26 Street, Room 208  
Miami, Florida 33175-2474  
T (786) 315-2590 F (786) 315-2599  
[www.miamidade.gov/economy](http://www.miamidade.gov/economy)

**Eagle Roofing Products LLC**  
1575 East C.R. 470  
Sumterville, FL 33585

**SCOPE:**

This NOA is being issued under the applicable rules and regulations governing the use of construction materials. The documentation submitted has been reviewed and accepted by Miami-Dade County RER -Product Control Section to be used in Miami-Dade County and other areas where allowed by the Authority Having Jurisdiction (AHJ).

This NOA shall not be valid after the expiration date stated below. The Miami-Dade County Product Control Section (in Miami-Dade County) and/or the AHJ (in areas other than Miami-Dade County) reserve the right to have this product or material tested for quality assurance purposes. If this product or material fails to perform in the accepted manner, the manufacturer will incur the expense of such testing and the AHJ may immediately revoke, modify, or suspend the use of such product or material within their jurisdiction. RER reserves the right to revoke this acceptance, if it is determined by Miami-Dade County Product Control Section that this product or material fails to meet the requirements of the applicable building code.

This product is approved as described herein, and has been designed to comply with the Florida Building Code including the High Velocity Hurricane Zone of the Florida Building Code.

**DESCRIPTION: High Profile Concrete Tile**

**LABELING:** Each unit shall bear a permanent label with the manufacturer's name or logo, city, state and following statement: "Miami-Dade County Product Control Approved", unless otherwise noted herein.

**RENEWAL** of this NOA shall be considered after a renewal application has been filed and there has been no change in the applicable building code negatively affecting the performance of this product.

**TERMINATION** of this NOA will occur after the expiration date or if there has been a revision or change in the materials, use, and/or manufacture of the product or process. Misuse of this NOA as an endorsement of any product, for sales, advertising or any other purposes shall automatically terminate this NOA. Failure to comply with any section of this NOA shall be cause for termination and removal of NOA.

**ADVERTISEMENT:** The NOA number preceded by the words Miami-Dade County, Florida, and followed by the expiration date may be displayed in advertising literature. If any portion of the NOA is displayed, then it shall be done in its entirety.

**INSPECTION:** A copy of this entire NOA shall be provided to the user by the manufacturer or its distributors and shall be available for inspection at the job site at the request of the Building Official.

This NOA revises NOA No.18-0829.04 and consists of pages 1 through 9.  
The submitted documentation was reviewed by *Freddy Semino*



NOA No. 19-1030.04  
Expiration Date: 10/05/21  
Approval Date: 02/04/21  
Page 1 of 9

## ROOFING ASSEMBLY APPROVAL

**Category:** Roofing  
**Sub Category:** Roofing Tiles  
**Material:** Concrete

### 1. SCOPE:

This approves a new roofing system using **High Profile Concrete Tile** as manufactured by **Eagle Roofing Products LLC** in **Sumterville, FL** and described in Section 2 of this Notice of Acceptance. For use in locations where the pressure requirements, as determined by applicable Building Code, do not exceed the design pressure values obtained by calculations in compliance with RAS 127 using the values listed in section 4 herein. The attachment calculations shall be done as a moment based system.

### 2. PRODUCT DESCRIPTION:

| <u>Manufactured by Applicant</u> | <u>Dimensions</u>                                      | <u>Test Specifications</u>      | <u>Product Description</u>   |
|----------------------------------|--|---------------------------------|--|
| High Profile Concrete Tile       | Length = 17"<br>Width = 12 1/4"<br>Thickness = 1/2"    | TAS 112<br>Type 1a<br>Class III | High profile concrete roof tile. For direct deck or battened nail-on applications.   |
| Trim Pieces                      | Length = varies<br>Width = varies<br>varying thickness | TAS 112                         | Accessory trim, concrete roof pieces for use at hips, rakes, ridges and valley terminations. Manufactured for each tile profile. |

### 2.1 PRODUCTS MANUFACTURED BY OTHERS

| <u>Product Name</u>                                      | <u>Product Description</u>                             | <u>Manufacturer (With Current NOA)</u> |
|--|--|--|
| ICP Adhesives Polyset® AH-160                            | Two component polyurethane foam adhesive.              | ICP Adhesives and Sealants, Inc.       |
| TILE BOND™ Roof Tile Adhesive                            | Single component polyurethane foam roof tile adhesive. | DuPont de Nemours, Inc.                |
| DAP Foam Touch N Seal<br>StormBond® 2 Roof Tile Adhesive | Two component polyurethane foam adhesive.              | DAP Foam, Inc.                         |

### 2.2 MANUFACTURING LOCATION

2.2.1. Sumterville, FL



NOA No. 19-1030.04  
Expiration Date: 10/05/21  
Approval Date: 02/04/21  
Page 2 of 9

### 2.3 EVIDENCE SUBMITTED:

| <u>Test Agency</u>                          | <u>Test Identifier</u>                             | <u>Test Name/Report</u>  | <u>Date</u>                      |
|---|--|--|----------------------------------|
| PRI Asphalt Technologies                    | ERPF-001-02-03                                     | TAS-112  | Aug. 2006                        |
| Redland Technologies                        | 7161-03<br>Appendix III                            | Static Uplift Testing<br>TAS 102 & 102(A)                        | Dec. 1991                        |
| Redland Technologies                        | Letter Dated Aug. 1,<br>1994                       | Wind Tunnel Testing<br>TAS 108 (Nail-On)                         | Aug. 1994                        |
| Redland Technologies                        | P09647-01  | Wind Tunnel Testing<br>TAS 108 (Mortar Set)                      | Aug. 1994                        |
| Redland Technologies                        | P0402  | Withdrawal Resistance Testing of screw<br>vs. smooth shank nails | Sept. 1993                       |
| The Center for Applied<br>Engineering, Inc. | 94-083   | Static Uplift Testing<br>TAS 101 (Adhesive Set)                  | April 1994                       |
| The Center for Applied<br>Engineering, Inc. | 94-084   | Static Uplift Testing<br>TAS 101 (Mortar Set)                    | May 1994                         |
| The Center for Applied<br>Engineering, Inc. | 25-7094-(3, 6 & 9)                                 | Static Uplift Testing<br>TAS 102                                 | Oct. 1994                        |
| The Center for Applied<br>Engineering, Inc. | 25-7120-(1 & 2)                                    | Static Uplift Testing<br>TAS 102                                 | Nov. 1994                        |
| The Center for Applied<br>Engineering, Inc. | 25-7183-(3 & 4)                                    | Static Uplift Testing<br>TAS 102                                 | Feb. 1995                        |
| The Center for Applied<br>Engineering, Inc. | 25-7214-(3, 4, &7)                                 | Static Uplift Testing<br>TAS 102                                 | March, 1995                      |
| The Center for Applied<br>Engineering, Inc. | 25-7804-4  | Static Uplift Testing<br>TAS 102                                 | Sept. 1996                       |
| Celotex Corporation<br>Testing Services     | 520111-3   | Static Uplift Testing<br>TAS 101                                 | Dec. 1998                        |
| Celotex Corporation<br>Testing Services     | 520191-2-1   | Static Uplift Testing<br>TAS 101                                 | March 1999                       |
| Walker Engineering, Inc.                    | Calculations                                       | Aerodynamic Multiplier   | Sept. 2006                       |
| ATL of South Florida                        | RT1211.02-15                                       | TAS-112  | 12/17/15                         |
| ATL of South Florida                        | RT0706.03.17                                       | TAS-112  | 09/25/17                         |
| PRI Construction Materials                  | DAPF-001-02-01<br>DAPF-004-02-03<br>DAPF-004-02-04 | Static Uplift Testing<br>(Adhesive)<br>TAS 101                   | 11/30/17<br>07/09/18<br>07/09/18 |
| NEMO ETC, LLC                               | 4c-DPBS-20-LSOTM-<br>01.D.R1                       | TAS 101  | 12/17/20                         |



**3. LIMITATIONS:**

- 3.1 Fire classification is not part of this acceptance.
- 3.2 For mortar or adhesive set tile applications, a static field uplift test in accordance with TAS 106 shall be required, refer to applicable Building Code.
- 3.3 Applicant shall retain the services of a Miami-Dade County Certified Laboratory to perform quarterly test in accordance with TAS 112, appendix 'A'. Such testing shall be submitted to the Miami-Dade County Product Control Section for review.
- 3.4 Minimum underlayment shall be in compliance with the applicable Roofing Applications Standards listed section 4.1 herein.
- 3.5 30/90 hot mopped underlayment applications may be installed perpendicular to the roof slope unless stated otherwise by the underlayment material manufacturers published literature.
- 3.6 This acceptance is for wood deck applications. Minimum deck requirements shall be in compliance with applicable Building Code.
- 3.7 All products listed herein shall have a quality assurance audit in accordance with the Florida Building Code and Rule 61G20-3 of the Florida Administrative Code.

**4. INSTALLATION**

- 4.1 Eagle Roofing Products LLC, High Profile Concrete Tile and its components shall be installed in strict compliance with Roofing Application Standard RAS 118, RAS 119 and RAS 120.
- 4.2 Data For Attachment Calculations

**Table 1: Average Weight (W) and Dimensions (l x w)**

| Tile Profile               | Weight-W (lbf) | Length-l (ft) | Width-w (ft) |
|----------------------------|----------------|---------------|--------------|
| High Profile Concrete Tile | 10             | 1.417         | 1.04         |

**Table 2: Aerodynamic Multipliers -  $\lambda$  (ft<sup>3</sup>)**

| Tile Profile               | $\lambda$ (ft <sup>3</sup> )<br>Batten Application | $\lambda$ (ft <sup>3</sup> )<br>Direct Deck Application |
|----------------------------|--|---|
| High Profile Concrete Tile | 0.300  | 0.277   |

**Table 3: Restoring Moments due to Gravity -  $M_g$  (ft-lbf)**

| Tile Profile               | 2" & 3":12 |             | 4":12"  |             | 5":12"  |             | 6":12"  |             | 7":12" or greater |             |
|----------------------------|------------|-------------|---------|-------------|---------|-------------|---------|-------------|-------------------|-------------|
|                            | Battens    | Direct Deck | Battens | Direct Deck | Battens | Direct Deck | Battens | Direct Deck | Battens           | Direct Deck |
| High Profile Concrete Tile | N/A        | 6.99        | 6.57    | 6.88        | 6.44    | 6.73        | 6.28    | 6.56        | 6.10              | 6.38        |



**Table 4: Attachment Resistance Expressed as a Moment - M<sub>r</sub> (ft-lbf)  
for Nail-On Systems**

| Tile Profile                  | Fastener Type                                     | Direct Deck<br>(min 15/32" plywood) | Direct Deck<br>(min. 19/32" plywood) | Battens |
|-------------------------------|---|-------------------------------------|--------------------------------------|---------|
| High Profile<br>Concrete Tile | 2-10d Ring Shank Nails                            | 28.6                                | 41.2                                 | 19.4    |
|                               | 1-10d Smooth or Screw<br>Shank Nail               | 5.1                                 | 6.8                                  | 2.8     |
|                               | 2-10d Smooth or Screw<br>Shank Nails              | 6.9                                 | 9.2                                  | 7.3     |
|                               | 1 #8 Screw  | 20.7                                | 20.7                                 | 18.1    |
|                               | 2 #8 Screw  | 43.2                                | 43.2                                 | 29.8    |
|                               | 1-10d Smooth or Screw<br>Shank Nail (Field Clip)  | 23.1                                | 23.1                                 | 19.0    |
|                               | 1-10d Smooth or Screw<br>Shank Nail (Eave Clip)   | 29.3                                | 29.3                                 | 24.0    |
|                               | 2-10d Smooth or Screw<br>Shank Nails (Field Clip) | 27.6                                | 27.6                                 | 38.6    |
|                               | 2-10d Smooth or Screw<br>Shank Nails (Eave Clip)  | 38.1                                | 38.1                                 | 41.8    |
|                               | 2-10d Ring Shank Nails <sup>1</sup>               | 33.1                                | 48.1                                 | 45.2    |

1. Installation with a 4" tile headlap and fasteners are located a min. of 2½" from head of tile.

**Table 5: Attachment Resistance Expressed as a Moment M<sub>r</sub> (ft-lbf)  
for Two Patty Adhesive Set Systems**

| Tile Profile               | Tile Application      | Minimum Attachment<br>Resistance   |
|----------------------------|-----------------------|--|
| High Profile Concrete Tile | Adhesive <sup>1</sup> | 19 <sup>2</sup><br>58 <sup>3</sup><br>29.3 <sup>4</sup><br>49 <sup>5</sup> |

1 See manufactures component approval for installation requirements.

2 Dupont De Nemours TILE BOND™ Roof Tile Adhesive weight per patty 8 grams.

3 Dupont De Nemours TILE BOND™ Roof Tile Adhesive weight per patty 10 and 20 grams.

4 ICP Adhesives Polyset - AH-160 weight per patty 8 grams.

5 DAP Foam Touch N Seal StormBond® 2 Roof Tile Adhesive weight per patty 8 grams.

**\*NOTE \***

For # 2 placement see Detail 3 B on page 8 of 9

For # 3 placement see Detail 3 C on page 9 of 9



**Table 6: Attachment Resistance Expressed as a Moment -  $M_f$  (ft-lbf)  
for Single Patty Adhesive Set Systems**

| Tile Profile   | Tile Application   | Minimum Attachment Resistance |
|--|--|-------------------------------|
| High Profile Concrete Tile   | Adhesive <sup>4</sup>  |                               |
| 4 See manufactures component approval for installation requirements. |  |                               |
| 5  | ICP Adhesives Polyset · AH-160 Large paddy placement of 63 grams                 | 66.5                          |
| 6  | ICP Adhesives Polyset · AH-160 Medium paddy placement of 24 grams                | 38.7                          |
| 7  | DAP Foam Touch N Seal StormBond® 2 Roof Tile Adhesive weight per paddy 60 grams. | 61                            |
| 8  | DAP Foam Touch N Seal StormBond® 2 Roof Tile Adhesive weight per paddy 30 grams. | 37                            |

**Table 7: Attachment Resistance Expressed as a Moment -  $M_f$  (ft-lbf)  
for Mortar Set Systems**

| Tile Profile                  | Tile Application        | Attachment Resistance |
|-------------------------------|-------------------------|-----------------------|
| High Profile Concrete Tile    | Mortar Set <sup>9</sup> | 24.5                  |
| 9 Tile-Tite Roof Tile Mortar. |                         |                       |

**5. LABELING :**

All tiles shall bear the imprint or identifiable marking of the manufacturer's name or logo (See **Detail Below**), or following statement: "Miami-Dade County Product Control Approved".



(LOCATED ON UNDERSIDE OF TILE)

OR

**EAGLE FL**

(LOCATED ON FRONTSIDE OF TILE)

**High Profile Concrete Tile LABEL, SUMTERVILLE PLANT**



NOA No. 19-1030.04  
Expiration Date: 10/05/21  
Approval Date: 02/04/21  
Page 6 of 9

## 6. BUILDING PERMIT REQUIREMENTS:

6.1 Application for building permit shall be accompanied by copies of the following:

6.1.1 This Notice of Acceptance.

6.1.2 Any other documents required by AHJ or applicable Building Code in order to properly evaluate the installation of this system.

### PROFILE DRAWING

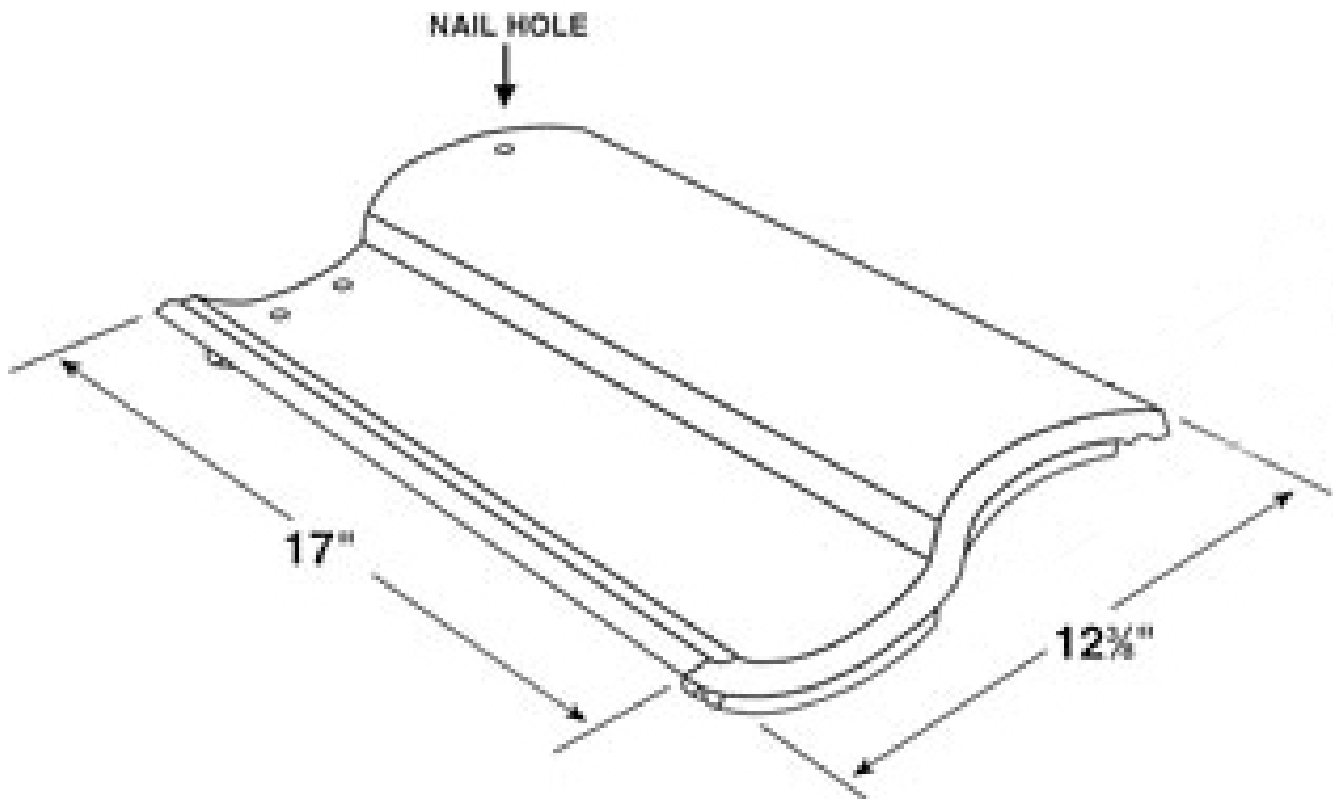

**High Profile Concrete Tile**

**DETAIL 3 B**



| Placement   | Min. Tile Contact Area, in <sup>2</sup> per Tile |
|---|--|
| <p><b>Attachment:</b> One (1) paddy, minimum 4-in. x 4-in. x 1-in. to underlayment and one (1) bead/paddy, minimum 1-in. x 1-in. x 8-in.</p> <p><b>Adhesive Rates:</b> 8 gram/paddy</p> | <p align="center">32</p>                         |



**DETAIL 3 C**



| <b>Placement</b>   | <b>Min. Tile Contact Area, in<sup>2</sup> per Tile</b> |
|--|--|
| <b>Attachment:</b> One (1) 1-in. x 1-in. x 8-in. paddy to the center of the tile underside (3" down from the headlap) mating to one (1) 1-in. x 1-in. x 8-in. paddy applied to the deck<br><b>Adhesive Rates:</b> 10 and 20 gram paddys respectively | 15   |

**END OF THIS ACCEPTANCE**